

R-HPTII-ZF Zinc Flake Throughbolt

Throughbolt anchor with corrosion-resistant coating for cracked and non-cracked concrete



Approvals and Reports

- ETA 17/0184



Product information

Features and benefits

- New generation of throughbolt with unique corrosion-resistant coating
- High performance in cracked and non-cracked concrete confirmed by ETA Option 1
- Highest quality ensures maximum load capability
- For applications requiring fire resistance up to 120 minutes
- Suitable for reduced embedment to avoid contact with reinforcement
- Embedment depth markings help to ensure precise installation of the anchor
- Design of R-HPTII allows drilling and installing directly through the fixture and helps to reduce installation time
- Fire resistant

Applications

- Cladding restraints
- Consoles
- Barriers
- Structural steel
- Curtain walling
- Handrails
- Heavy Plant
- Balustrading
- Passenger lifts
- Facades
- Racking systems
- Platforms
- Fencing & gates manufacturing and installation

Base materials

Approved for use in:

- Cracked concrete C20/25-C50/60
- Non-cracked concrete C20/25-C50/60
- Reinforced concrete
- Unreinforced concrete

Also suitable for use in:

- Natural Stone (after site testing)

Installation guide



1. Drill a hole of required diameter and depth
2. Clear the hole of drilling dust and debris (using blowpump or equivalent method)
3. Lightly tap the throughbolt through the fixture into hole with a hammer, until fixing depth is reached
4. Tighten to the recommended torque

Product information

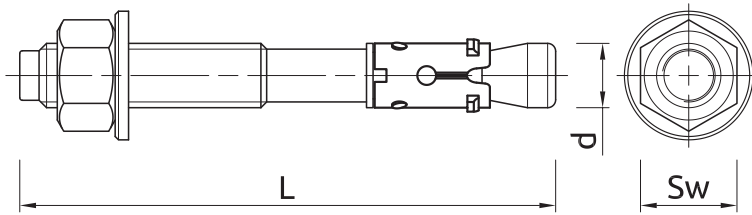

Size	Product Code	Anchor		Fixture		
		Diameter	Length	Max. thickness t_{fix} for:		Hole diameter
		d [mm]	L [mm]	$h_{nom,red}$ [mm]	$h_{nom,std}$ [mm]	d_f [mm]
M8	R-HPTIIZF-08065/15	8	65	15	-	9
	R-HPTIIZF-08080/15	8	80	30	15	9
	R-HPTIIZF-08100/35	8	100	50	35	9
	R-HPTIIZF-08115/50	8	115	65	50	9
M10	R-HPTIIZF-10065/5	10	65	5	-	11
	R-HPTIIZF-10080/20	10	80	20	-	11
	R-HPTIIZF-10095/15	10	95	35	15	11
	R-HPTIIZF-10115/35	10	115	55	35	11
M12	R-HPTIIZF-10130/50	10	130	70	50	11
	R-HPTIIZF-12080/5	12	80	5	-	13
	R-HPTIIZF-12100/5	12	100	25	5	13
	R-HPTIIZF-12120/25	12	120	45	25	13
M16	R-HPTIIZF-12135/40	12	135	60	40	13
	R-HPTIIZF-12150/55	12	150	75	55	13
	R-HPTIIZF-16105/10	16	105	10	-	18
	R-HPTIIZF-16140/20	16	140	40	20	18
M20	R-HPTIIZF-16180/60	16	180	80	60	18
	R-HPTIIZF16220/100	16	220	120	100	18
	R-HPTIIZF-20125/5	20	125	5	-	22
	R-HPTIIZF-20160/20	20	160	40	20	22
	R-HPTIIZF-20200/60	20	200	80	60	22

Installation data

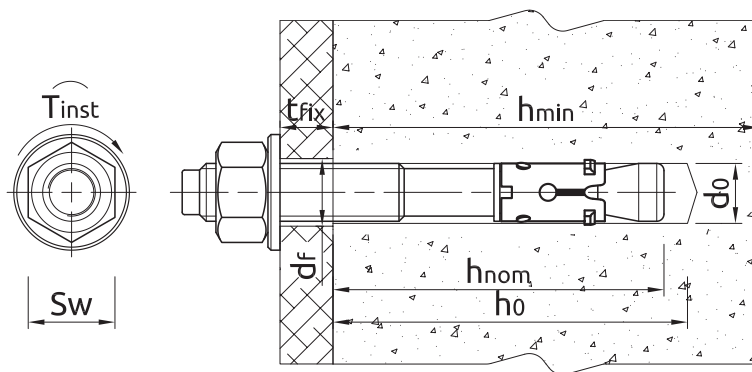

Size	M8	M10	M12	M16	M20		
Thread diameter	d	[mm]	8	10	12	16	20
Hole diameter in substrate	d_0	[mm]	8	10	12	16	20
Installation torque	T_{inst}	[Nm]	10	20	40	100	180
Wrench size	Sw	[mm]	13	17	19	24	30
External diameter of washer		[mm]	16	20	24	30	37

Installation data

Size			M8	M10	M12	M16	M20
STANDARD EMBEDMENT DEPTH							
Min. hole depth in substrate	$h_{0,s}$	[mm]	65	79	90	110	129
Min. installation depth	$h_{nom,s}$	[mm]	55	69	80	100	119
Min. substrate thickness	$h_{min,s}$	[mm]	100	120	140	170	200
Min. spacing (Non-cracked concrete)	$s_{min,s}$	[mm]	50	70	90	160	180
Min. spacing (Cracked concrete)	$s_{min,s}$	[mm]	50	70	90	160	180
Min. edge distance (Non-cracked concrete)	$c_{min,s}$	[mm]	40	50	65	85	100
Min. edge distance (Cracked concrete)	$c_{min,s}$	[mm]	40	45	65	90	100
REDUCED EMBEDMENT DEPTH							
Min. hole depth in substrate	$h_{0,r}$	[mm]	50	59	70	90	110
Min. installation depth	$h_{nom,r}$	[mm]	40	49	60	80	100
Min. substrate thickness	$h_{min,r}$	[mm]	100	100	100	130	160
Min. spacing (Non-cracked concrete)	$s_{min,r}$	[mm]	55	75	150	190	300
Min. spacing (Cracked concrete)	$s_{min,r}$	[mm]	55	75	150	190	300
Min. edge distance (Non-cracked concrete)	$c_{min,r}$	[mm]	45	60	70	100	160
Min. edge distance (Cracked concrete)	$c_{min,r}$	[mm]	40	50	80	110	120

Mechanical properties

Size			M8	M10	M12	M16	M20
Nominal ultimate tensile strength - tension	f_{uk}	[N/mm ²]	620	620	620	620	620
Nominal ultimate tensile strength - shear	f_{uk}	[N/mm ²]	520	520	520	520	520
Nominal yield strength - tension	f_{yk}	[N/mm ²]	531	531	531	531	531
Nominal yield strength - shear	f_{yk}	[N/mm ²]	416	416	416	416	416
Cross sectional area - tension	A_s	[mm ²]	25.5	40.7	60.1	106.6	162.9
Cross sectional area - shear	A_s	[mm ²]	38.9	61.7	89.6	165.2	259.1
Elastic section modulus	W_{el}	[mm ³]	34.3	68.3	119.6	299.5	588.3
Characteristic bending resistance	$M^0_{Rk,s}$	[Nm]	19	38	67	167	328
Design bending resistance	M	[Nm]	15	31	53	134	263

Basic performance data

Performance data for single anchor without influence of edge distance and spacing - ETAG 001

Size		M8	M10	M12	M16	M20
NON-CRACKED CONCRETE						
Standard embedment depth h_{ef}	[mm]	47.00	59.00	68.00	85.00	99.00
Reduced embedment depth h_{ef}	[mm]	32.00	39.00	48.00	65.00	80.00
CRACKED CONCRETE						
Standard embedment depth h_{ef}	[mm]	47.00	59.00	68.00	85.00	99.00
Reduced embedment depth h_{ef}	[mm]	32.00	39.00	48.00	65.00	80.00

Basic performance data

Size		M8	M10	M12	M16	M20
MEAN ULTIMATE LOAD						
TENSION LOAD $N_{Ru,m}$						
NON-CRACKED CONCRETE						
Standard embedment depth	[kN]	12.40	20.60	27.70	45.50	64.80
Reduced embedment depth	[kN]	9.60	13.60	17.60	34.50	47.10
CRACKED CONCRETE						
Standard embedment depth	[kN]	7.50	12.50	19.90	27.30	41.90
Reduced embedment depth	[kN]	4.80	8.60	12.80	26.80	32.70
SHEAR LOAD $V_{Ru,m}$						
NON-CRACKED CONCRETE						
Standard embedment depth	[kN]	12.20	19.20	28.00	51.50	80.90
Reduced embedment depth	[kN]	12.20	19.20	28.00	51.50	80.90
CRACKED CONCRETE						
Standard embedment depth	[kN]	12.20	19.20	28.00	51.50	80.90
Reduced embedment depth	[kN]	12.20	19.20	28.00	51.50	80.90
CHARACTERISTIC LOAD						
TENSION LOAD N_{Rk}						
NON-CRACKED CONCRETE						
Standard embedment depth	[kN]	9.00	12.00	20.00	35.00	49.74
Reduced embedment depth	[kN]	7.50	9.00	12.00	26.46	36.13
CRACKED CONCRETE						
Standard embedment depth	[kN]	5.00	9.00	12.00	20.00	30.00
Reduced embedment depth	[kN]	3.00	6.00	9.00	16.00	25.76
SHEAR LOAD V_{Rk}						
NON-CRACKED CONCRETE						
Standard embedment depth	[kN]	9.10	15.70	23.70	47.10	60.60
Reduced embedment depth	[kN]	9.10	12.30	16.79	47.10	60.60
CRACKED CONCRETE						
Standard embedment depth	[kN]	9.10	15.70	23.70	47.10	60.60
Reduced embedment depth	[kN]	6.52	8.77	11.97	37.73	51.52
DESIGN LOAD						
TENSION LOAD N_{Rd}						
NON-CRACKED CONCRETE						
Standard embedment depth	[kN]	5.00	8.00	13.30	23.33	33.16
Reduced embedment depth	[kN]	4.17	5.00	8.00	17.64	24.09
CRACKED CONCRETE						
Standard embedment depth	[kN]	2.78	6.00	8.00	13.33	20.00
Reduced embedment depth	[kN]	1.67	3.33	6.00	10.67	17.17
SHEAR LOAD V_{Rd}						
NON-CRACKED CONCRETE						
Standard embedment depth	[kN]	7.28	12.56	18.96	37.68	48.48
Reduced embedment depth	[kN]	6.09	8.20	11.20	35.29	48.18
CRACKED CONCRETE						
Standard embedment depth	[kN]	7.28	10.88	18.96	37.62	47.28
Reduced embedment depth	[kN]	4.34	5.85	7.98	25.15	34.35

Basic performance data

Size		M8	M10	M12	M16	M20
RECOMMENDED LOAD						
TENSION LOAD N_{rec}						
NON-CRACKED CONCRETE						
Standard embedment depth	[kN]	3.57	5.71	9.52	16.67	23.69
Reduced embedment depth	[kN]	2.98	3.57	5.71	12.60	17.21
CRACKED CONCRETE						
Standard embedment depth	[kN]	1.98	4.29	5.71	9.52	14.29
Reduced embedment depth	[kN]	1.19	2.38	4.29	7.62	12.27
SHEAR LOAD V_{rec}						
NON-CRACKED CONCRETE						
Standard embedment depth	[kN]	5.20	8.97	13.54	26.91	34.63
Reduced embedment depth	[kN]	4.35	5.86	8.00	25.20	34.41
CRACKED CONCRETE						
Standard embedment depth	[kN]	5.20	7.77	13.54	26.87	33.77
Reduced embedment depth	[kN]	3.10	4.18	5.70	17.97	24.53

Design performance data

Standard embedment depth

(-) failure is not decisive

Size			M8	M10	M12	M16	M20
Effective embedment depth	h_{ef}	[mm]	47.00	59.00	68.00	85.00	99.00
TENSION LOAD							
STEEL FAILURE							
Characteristic resistance	$N_{Rk,s}$	[kN]	11.00	17.50	25.80	45.80	70.00
Partial safety factor	γ_{Ms}	-	1.40	1.40	1.40	1.40	1.40
PULL-OUT FAILURE; NON-CRACKED CONCRETE C20/25							
Characteristic resistance	$N_{Rk,p}$	[kN]	9.00	12.00	20.00	35.00	-
PULL-OUT FAILURE; CRACKED CONCRETE C20/25							
Characteristic resistance	$N_{Rk,p}$	[kN]	5.00	9.00	12.00	20.00	30.00
PULL-OUT FAILURE							
Installation safety factor	γ_2	-	1.20	1.00	1.00	1.00	1.00
Increasing factors for $N_{Rd,p}$ - C30/37	ψ_c	-	1.12	1.22	1.00	1.14	1.07
Increasing factors for $N_{Rd,p}$ - C40/50	ψ_c	-	1.22	1.44	1.00	1.28	1.14
Increasing factors for $N_{Rd,p}$ - C50/60	ψ_c	-	1.33	1.67	1.00	1.43	1.21
CONCRETE CONE FAILURE							
Factor for cracked concrete	k	-	7.20	7.20	7.20	7.20	7.20
Factor for cracked concrete	$k_{cr,N}$	-	7.70	7.70	7.70	7.70	7.70
Factor for non-cracked concrete	k	-	10.10	10.10	10.10	10.10	10.10
Factor for non-cracked concrete	$k_{ucr,N}$	-	11.00	11.00	11.00	11.00	11.00
Installation safety factor	γ_2	-	1.20	1.00	1.00	1.00	1.00
Spacing	$s_{cr,N}$	[mm]	141.00	177.00	204.00	255.00	297.00
Edge distance	$c_{cr,N}$	[mm]	71.00	89.00	102.00	128.00	149.00
CONCRETE SPLITTING FAILURE							
Spacing	$s_{cr,sp}$	[mm]	220.00	300.00	340.00	430.00	530.00
Edge distance	$c_{cr,sp}$	[mm]	110.00	150.00	170.00	215.00	265.00
Installation safety factor	γ_2	-	1.20	1.00	1.00	1.00	1.00

Design performance data

Size			M8	M10	M12	M16	M20
SHEAR LOAD							
STEEL FAILURE							
Characteristic resistance without lever arm	$V_{Rk,s}$	[kN]	9.10	15.70	23.70	47.10	60.60
Ductility factor	k_γ	-	0.80	0.80	0.80	0.80	0.80
Characteristic resistance with lever arm	$M_{Rk,s}$	[Nm]	22.00	45.00	79.00	200.00	389.00
Partial safety factor	γ_{Ms}	-	1.25	1.25	1.25	1.25	1.25
CONCRETE PRY-OUT FAILURE							
Factor	k	-	1.00	1.00	2.00	2.00	2.00
Installation safety factor	γ_2	-	1.00	1.00	1.00	1.00	1.00
CONCRETE EDGE FAILURE							
Effective length of anchor	ℓ_f	[mm]	47.00	59.00	68.00	85.00	99.00
Anchor diameter	d_{nom}	[mm]	8.00	10.00	12.00	16.00	20.00
Installation safety factor	γ_2	-	1.00	1.00	1.00	1.00	1.00

Design performance data

Resistance to tension and shear loads under fire exposure - Standard embedment depth

Size			M8	M10	M12	M16	M20
TENSION LOAD							
Spacing	S_{cr}	[mm]	188.00	236.00	272.00	340.00	369.00
Edge distance	c_{cr}	[mm]	94.00	118.00	136.00	170.00	198.00
R (for EI) = 30 min							
TENSION LOAD							
STEEL FAILURE							
Characteristic resistance	$N_{Rk,s}$	[kN]	0.40	0.90	1.70	3.10	4.90
PULL-OUT FAILURE							
Characteristic resistance	$N_{Rk,p}$	[kN]	1.30	2.30	3.00	5.00	-
SHEAR LOAD							
STEEL FAILURE							
Characteristic resistance without lever arm	$V_{Rk,s}$	[kN]	0.40	0.90	1.70	3.10	4.90
Characteristic resistance with lever arm	$M_{Rk,s}$	[Nm]	0.40	1.10	2.60	6.70	13.00
R (for EI) = 60 min							
TENSION LOAD							
STEEL FAILURE							
Characteristic resistance	$N_{Rk,s}$	[kN]	0.30	0.80	1.30	2.40	3.70
PULL-OUT FAILURE							
Characteristic resistance	$N_{Rk,p}$	[kN]	1.30	2.30	3.00	5.00	-
SHEAR LOAD							
STEEL FAILURE							
Characteristic resistance without lever arm	$V_{Rk,s}$	[kN]	0.30	0.80	1.30	2.40	3.70
Characteristic resistance with lever arm	$M_{Rk,s}$	[Nm]	0.30	1.00	2.00	5.00	9.70
R (for EI) = 90 min							
TENSION LOAD							
STEEL FAILURE							
Characteristic resistance	$N_{Rk,s}$	[kN]	0.30	0.60	1.10	2.00	3.20
PULL-OUT FAILURE							
Characteristic resistance	$N_{Rk,p}$	[kN]	1.30	2.30	3.00	5.00	-
SHEAR LOAD							
STEEL FAILURE							
Characteristic resistance without lever arm	$V_{Rk,s}$	[kN]	0.30	0.60	1.10	2.00	3.20
Characteristic resistance with lever arm	$M_{Rk,s}$	[Nm]	0.30	0.70	1.70	4.30	8.40
R (for EI) = 120 min							
TENSION LOAD							
STEEL FAILURE							
Characteristic resistance	$N_{Rk,s}$	[kN]	0.20	0.50	0.80	1.60	2.50
PULL-OUT FAILURE							
Characteristic resistance	$N_{Rk,p}$	[kN]	1.00	1.80	2.40	4.00	-
SHEAR LOAD							
STEEL FAILURE							
Characteristic resistance without lever arm	$V_{Rk,s}$	[kN]	0.20	0.50	0.80	1.60	2.50
Characteristic resistance with lever arm	$M_{Rk,s}$	[Nm]	0.20	0.60	1.30	3.30	6.50

Design performance data

Allowable values for resistance in case of Seismic performance category C1 - Standard embedment depth

Size			M8	M10	M12	M16	M20
Effective embedment depth	h_{ef}	[mm]	47.00	59.00	68.00	85.00	99.00
TENSION LOAD, STEEL FAILURE							
Characteristic resistance	$N_{Rk,s}$	[kN]	11.00	17.50	25.80	45.80	70.00
Partial safety factor	$\gamma_{MsN,seisC1}$	-	1.40				
TENSION LOAD, PULL-OUT FAILURE							
Characteristic resistance	$N_{Rk,p}$	[kN]	5.00	9.00	12.00	20.00	30.00
Partial safety factor	$\gamma_{Mp,seisC1}$	-	1.80	1.50			
SHEAR LOAD, STEEL FAILURE							
Characteristic resistance without lever arm	$V_{Rk,s}$	[kN]	5.20	9.40	23.80	33.30	55.10
Partial safety factor	$\gamma_{MsV,seisC1}$	-	1.25				

Allowable values for resistance in case of Seismic performance category C2 - Standard embedment depth

Size			M10	M12	M16
Effective embedment depth	h_{ef}	[mm]	59.00	68.00	85.00
TENSION LOAD, STEEL FAILURE					
Characteristic resistance	$N_{Rk,s}$	[kN]	17.50	25.80	45.80
Partial safety factor	$\gamma_{MsN,seisC2}$	-	1.40		
TENSION LOAD, PULL-OUT FAILURE					
Characteristic resistance	$N_{Rk,p}$	[kN]	3.40	7.00	10.90
Partial safety factor	$\gamma_{Mp,seisC2}$	-	1.50		
SHEAR LOAD, STEEL FAILURE					
Characteristic resistance without lever arm	$V_{Rk,s}$	[kN]	9.20	11.10	28.20
Partial safety factor	$\gamma_{MsV,seisC2}$	-	1.25		

Design performance data

Reduced embedment depth

(-) failure is not decisive

Size			M8	M10	M12	M16	M20
Effective embedment depth	h_{ef}	[mm]	32.00	39.00	48.00	65.00	80.00
TENSION LOAD							
STEEL FAILURE							
Characteristic resistance	$N_{Rk,s}$	[kN]	11.00	17.50	25.80	45.80	70.00
Partial safety factor	γ_{Ms}	-	1.40	1.40	1.40	1.40	1.40
PULL-OUT FAILURE; NON-CRACKED CONCRETE C20/25							
Characteristic resistance	$N_{Rk,p}$	[kN]	7.50	9.00	12.00	-	-
PULL-OUT FAILURE; CRACKED CONCRETE C20/25							
Characteristic resistance	$N_{Rk,p}$	[kN]	3.00	6.00	9.00	16.00	-
PULL-OUT FAILURE							
Installation safety factor	γ_2	-	1.20	1.20	1.00	1.00	1.00
Increasing factors for $N_{Rd,p}$ - C30/37	ψ_c	-	1.20	1.16	1.22	1.11	1.12
Increasing factors for $N_{Rd,p}$ - C40/50	ψ_c	-	1.40	1.33	1.44	1.22	1.26
Increasing factors for $N_{Rd,p}$ - C50/60	ψ_c	-	1.60	1.50	1.67	1.33	1.39
CONCRETE CONE FAILURE							
Factor for cracked concrete	k	-	7.20	7.20	7.20	7.20	7.20
Factor for cracked concrete	$k_{cr,N}$	-	7.70	7.70	7.70	7.70	7.70
Factor for non-cracked concrete	k	-	10.10	10.10	10.10	10.10	10.10
Factor for non-cracked concrete	$k_{ucr,N}$	-	11.00	11.00	11.00	11.00	11.00
Installation safety factor	γ_2	-	1.20	1.20	1.00	1.00	1.00
Spacing	$s_{cr,N}$	[mm]	96.00	117.00	144.00	195.00	240.00
Edge distance	$c_{cr,N}$	[mm]	48.00	59.00	72.00	98.00	120.00
CONCRETE SPLITTING FAILURE							
Spacing	$s_{cr,sp}$	[mm]	170.00	200.00	250.00	320.00	410.00
Edge distance	$c_{cr,sp}$	[mm]	85.00	100.00	125.00	160.00	205.00
Installation safety factor	γ_2	-	1.20	1.20	1.00	1.00	1.00
SHEAR LOAD							
STEEL FAILURE							
Characteristic resistance without lever arm	$V_{Rk,s}$	[kN]	9.10	15.70	23.70	47.10	60.60
Ductility factor	k_γ	-	0.80	0.80	0.80	0.80	0.80
Characteristic resistance with lever arm	$M_{Rk,s}$	[Nm]	22.00	45.00	79.00	200.00	389.00
Partial safety factor	γ_{Ms}	-	1.25	1.25	1.25	1.25	1.25
CONCRETE PRY-OUT FAILURE							
Factor	k	-	1.00	1.00	1.00	2.00	2.00
Installation safety factor	γ_2	-	1.00	1.00	1.00	1.00	1.00
CONCRETE EDGE FAILURE							
Effective length of anchor	ℓ_f	[mm]	32.00	39.00	48.00	65.00	80.00
Anchor diameter	d_{nom}	[mm]	8.00	10.00	12.00	16.00	20.00
Installation safety factor	γ_2	-	1.00	1.00	1.00	1.00	1.00

Design performance data

Resistance to tension and shear loads under fire exposure - Reduced embedment depth

Size			M8	M10	M12	M16	M20
TENSION LOAD							
Spacing	S_{cr}	[mm]	128.00	156.00	192.00	260.00	320.00
Edge distance	c_{cr}	[mm]	64.00	78.00	96.00	130.00	160.00
R (for EI) = 30 min							
TENSION LOAD							
STEEL FAILURE							
Characteristic resistance	$N_{Rk,s}$	[kN]	0.40	0.90	1.70	3.10	4.90
PULL-OUT FAILURE							
Characteristic resistance	$N_{Rk,p}$	[kN]	0.80	1.50	2.30	4.00	-
SHEAR LOAD							
STEEL FAILURE							
Characteristic resistance without lever arm	$V_{Rk,s}$	[kN]	0.40	0.90	1.70	3.10	4.90
Characteristic resistance with lever arm	$M_{Rk,s}$	[Nm]	0.40	1.10	2.60	6.70	13.00
R (for EI) = 60 min							
TENSION LOAD							
STEEL FAILURE							
Characteristic resistance	$N_{Rk,s}$	[kN]	0.30	0.80	1.30	2.40	3.70
PULL-OUT FAILURE							
Characteristic resistance	$N_{Rk,p}$	[kN]	0.80	1.50	2.30	4.00	-
SHEAR LOAD							
STEEL FAILURE							
Characteristic resistance without lever arm	$V_{Rk,s}$	[kN]	0.30	0.80	1.30	2.40	3.70
Characteristic resistance with lever arm	$M_{Rk,s}$	[Nm]	0.30	1.00	2.00	5.00	9.70
R (for EI) = 90 min							
TENSION LOAD							
STEEL FAILURE							
Characteristic resistance	$N_{Rk,s}$	[kN]	0.30	0.60	1.10	2.00	3.20
PULL-OUT FAILURE							
Characteristic resistance	$N_{Rk,p}$	[kN]	0.80	1.50	2.30	4.00	-
SHEAR LOAD							
STEEL FAILURE							
Characteristic resistance without lever arm	$V_{Rk,s}$	[kN]	0.30	0.60	1.10	2.00	3.20
Characteristic resistance with lever arm	$M_{Rk,s}$	[Nm]	0.30	0.70	1.70	4.30	8.40
R (for EI) = 120 min							
TENSION LOAD							
STEEL FAILURE							
Characteristic resistance	$N_{Rk,s}$	[kN]	0.20	0.50	0.80	1.60	2.50
PULL-OUT FAILURE							
Characteristic resistance	$N_{Rk,p}$	[kN]	0.60	1.20	1.80	3.20	-
SHEAR LOAD							
STEEL FAILURE							
Characteristic resistance without lever arm	$V_{Rk,s}$	[kN]	0.20	0.50	0.80	1.60	2.50
Characteristic resistance with lever arm	$M_{Rk,s}$	[Nm]	0.20	0.60	1.30	3.30	6.50

Design performance data

Allowable values for resistance in case of Seismic performance category C1 - Reduced embedment depth

Size			M8	M10	M12	M16	M20
Effective embedment depth	h_{ef}	[mm]	32.00	39.00	48.00	65.00	80.00
TENSION LOAD, STEEL FAILURE							
Characteristic resistance	$N_{Rk,s}$	[kN]	11.00	17.50	25.80	45.80	70.00
Partial safety factor	$\gamma_{MsN,seisC1}$	-	1.40				
TENSION LOAD, PULL-OUT FAILURE							
Characteristic resistance	$N_{Rk,p}$	[kN]	3.00	6.00	9.00	16.00	-
Partial safety factor	$\gamma_{Mp,seisC1}$	-	1.80		1.50		
SHEAR LOAD, STEEL FAILURE							
Characteristic resistance without lever arm	$V_{Rk,s}$	[kN]	-		23.80	33.30	55.10
Partial safety factor	$\gamma_{MsV,seisC1}$	-	1.25				

Product commercial data

Size	Product Code	Anchor		Quantity [pcs]			Weight [kg]			Bar Codes
		Diameter [mm]	Length [mm]	Box	Outer	Pallet	Box	Outer	Pallet	
M8	R-HPTIIZF-08065/15 ¹⁾	8	65	100	100	16000	2.8	2.8	474.6	5906675022840
	R-HPTIIZF-08080/15 ¹⁾	8	80	100	100	16000	3.2	3.2	544.7	5906675022857
	R-HPTIIZF-08100/35 ¹⁾	8	100	100	100	12000	3.9	3.9	494.3	5906675034881
	R-HPTIIZF-08115/50 ¹⁾	8	115	100	100	16000	4.3	4.3	711.8	5906675022871
M10	R-HPTIIZF-10065/5 ¹⁾	10	65	50	50	8000	2.4	2.4	409.4	5906675022888
	R-HPTIIZF-10080/20 ¹⁾	10	80	50	50	8000	2.8	2.8	471.1	5906675022895
	R-HPTIIZF-10095/15 ¹⁾	10	95	50	50	8000	3.1	3.1	528.2	5906675022901
	R-HPTIIZF-10115/35 ¹⁾	10	115	50	50	6000	3.6	3.6	463.3	5906675022918
	R-HPTIIZF-10130/50 ¹⁾	10	130	50	50	6000	4.0	4.0	510.1	5906675022925
M12	R-HPTIIZF-12080/5 ¹⁾	12	80	50	50	8000	4.1	4.1	682.0	5906675022932
	R-HPTIIZF-12100/5 ¹⁾	12	100	50	50	8000	4.8	4.8	794.3	5906675022949
	R-HPTIIZF-12120/25 ¹⁾	12	120	50	50	6000	5.4	5.4	679.8	5906675022956
	R-HPTIIZF-12135/40 ¹⁾	12	135	50	50	6000	6.1	6.1	758.9	5906675022963
	R-HPTIIZF-12150/55 ¹⁾	12	150	50	50	4000	6.6	6.6	557.2	5906675022970
M16	R-HPTIIZF-16105/10 ¹⁾	16	105	25	25	4000	4.6	4.6	765.7	5906675022987
	R-HPTIIZF-16140/20 ¹⁾	16	140	25	25	4000	5.7	5.7	941.2	5906675022994
	R-HPTIIZF-16180/60 ¹⁾	16	180	25	25	3000	7.1	7.1	883.3	5906675023007
	R-HPTIIZF-16220/100 ¹⁾	16	220	25	25	3000	8.4	8.4	1041.5	5906675023014
M20	R-HPTIIZF-20125/5 ¹⁾	20	125	25	25	3000	8.2	8.2	1013.3	5906675023021
	R-HPTIIZF-20160/20 ¹⁾	20	160	25	25	3000	10.1	10.1	1245.4	5906675023038
	R-HPTIIZF-20200/60 ¹⁾	20	200	10	10	3000	4.9	4.9	1492.2	5906675023045

1) ETA 17/0184